

Electric Check List

Make a request in writing to connect to the Berlin Borough Electric system. Include the type of connection, overhead, underground or underground to mobile home.

Temporary Electric Service – cost is \$300 includes disconnect and reconnect.

Choose between:

Overhead electric

Complete the builder install request form.

Cost is \$50.00 Connection Fee.

Underground electric

Complete the builder install request form.

Complete the application for underground electric service.

Cost is \$50.00 connection fee plus the \$1.00/ft service protection fee.

Present form to the Executive Borough Secretary for approval.

After approval follow Instructions for Underground electric.

Preparation/Installation is the customers responsibility.

There needs to be an inspection on the ditch and pipe before line is pulled through. Inspection of ditch and pipe is required, by the

Borough Electrician, before line is pulled.

Underground electric for Mobile Home

Complete the builder install request form.

Complete the application for underground electric service.

Cost is \$50.00 connection fee plus the \$1.00/ft service protection fee.

Present form to the Executive Borough Secretary for approval.

After approval follow instructions for mobile home electric preparation/installation customer responsibility.

MUNICIPAL LIGHT SYSTEM

BOROUGH OF BERLIN

APPLICATION FOR UNDERGROUND ELECTRIC SERVICE

Name of Customer _____ Date _____

Service Location _____

Customer Address _____

Requirements: Customer must provide the trench and backfill the trench in accordance with the attached specifications. The mapping and staking of the underground cable shall be accomplished by the Borough Engineer and any costs incurred shall be paid by the applicant/customer.

Billing: \$1.00 per foot x total footage _____ \$ _____

Special Additional Charges (extra cost for _____) \$ _____

Total \$ _____

The Municipal Light System is hereby requested to furnish the undersigned with electric service at the above address.

This application shall not be binding upon the Municipal Light System until accepted by the System, and shall not be modified or affected by any promise, agreement, or representation by any agent or employee of the System made before or after signing, unless incorporated in writing herein before acceptance by the Municipal Light System.

This application, when accepted, shall constitute a contract between the parties hereto, which shall bind and inure to the benefit of the heirs, executors, administrators, successors or assigns, as the case may be, of the respective parties hereto, but neither customer nor customer's assigns shall assign any rights hereunder without the written consent of the Municipal Light System.

The undersigned grants permission for the installation of underground facilities and it is further agreed that all facilities installed by the Municipal Light System under this application shall remain the property of the Municipal Light System. The Municipal Light System shall have the right to enter the undersigned's premises at all reasonable times to construct, repair and maintain the facilities and upon failure of the undersigned to pay for any charges due hereunder, the Municipal Light System shall have the right to remove said facilities.

The applicant, heirs, executors, administrators, successors, or assigns, as the case may be, will hold harmless the Municipal Light System of any liability arising as a result of contact with the underground electric service by other than Municipal Light System personnel.

MUNICIPAL LIGHT SYSTEM

Received By

Date

Customer Signature

ACCEPTED:

Signature

Date

Signature

Date

Title

Title

Additionally for a customer installed and owned underground service lateral, if a customer increases the service lateral length or load, the customer is responsible to verify that ampacity, voltage drop, and voltage flicker limitations are suitable to serve the load. If load is being added, the customer shall advise the Company so that the Company can ensure all Company associated facilities are adequate to serve the increased load.

No fence, guardrail, wall, or other obstruction shall be placed near pad-mounted equipment (e.g., transformers, handholes, pedestals, switchgear) that would limit the Company from performing maintenance or repair on the equipment. This includes any tree, shrub, bush, or other vegetation that would have to be removed in order to operate, maintain, or replace equipment. The minimum clearance is three (3) feet from the back and sides, and ten (10) feet from the front of all pad-mounted equipment or any pad-mounted switchgear doors. Refer to Exhibits 22 and 23. Additionally, a customer shall not cover (even partially) any of these devices with plants, mulch, dirt, rocks, artificial rocks, or other landscaping as this prevents them from being quickly located, safely operated, as well as accelerating their corrosion. Company shall not be responsible for replacing shrubs, plants, fences, wall screenings, or other obstructions that need to be removed for maintenance or restoration work.

6.2 Underground Services from Overhead Lines

Refer to Exhibits 8, 9, and 10 for typical installations.

When it becomes necessary for the Company to replace a pole, upon which a customer-owned underground service lateral terminates, the necessary changes to the underground service conductors shall be made by the customer at the customer's expense. (Some exceptions may apply in certain cases involving governmental roadway improvement projects.)

6.3 Underground Services in Underground Residential Areas

For single-phase customer-owned underground services at 400 amps or less, the customer shall install only one set of service cables sized for the expected load. Multiple or parallel sets of cables are not acceptable for services at 400 amps or less. Refer to Exhibit 1 and Exhibit 8.

For services greater than 400 amps, the customer shall consult the Company as soon as possible during the building design stage to discuss the multiple or parallel cable service requirements.

Due to connector physical limitations, cable size shall be limited to 750 kcmil when terminating in a handhole, pedestal, or in a single-phase pad-mounted transformer.

6.4 Underground Services in Underground Commercial Areas

The customer shall provide the Company with suitable space at a location designated by the Company to accommodate the necessary transformation and switching equipment required to supply the customer's load. Space requirements may vary depending on the customer's load and service requirements, as well as the availability of Company facilities in the area. It is therefore imperative that the customer contact the Company as soon as practical in the customer's electrical design/planning stage to ensure that appropriate accommodations can be made for the required Company facilities.

When no suitable outdoor location is available, other options may be considered. Those options will require written approval from the Manager of Regional Engineering Services. The Company's equipment shall be accessible at all times. Special design requirements shall be adhered to so that the appropriate safety, maintenance, and operating conditions can be satisfied. As soon as possible during the building design stage, the customer shall consult the Company to discuss any special needs and design specifications (Company, OSHA, NESC, NFPA, NEC, etc.).

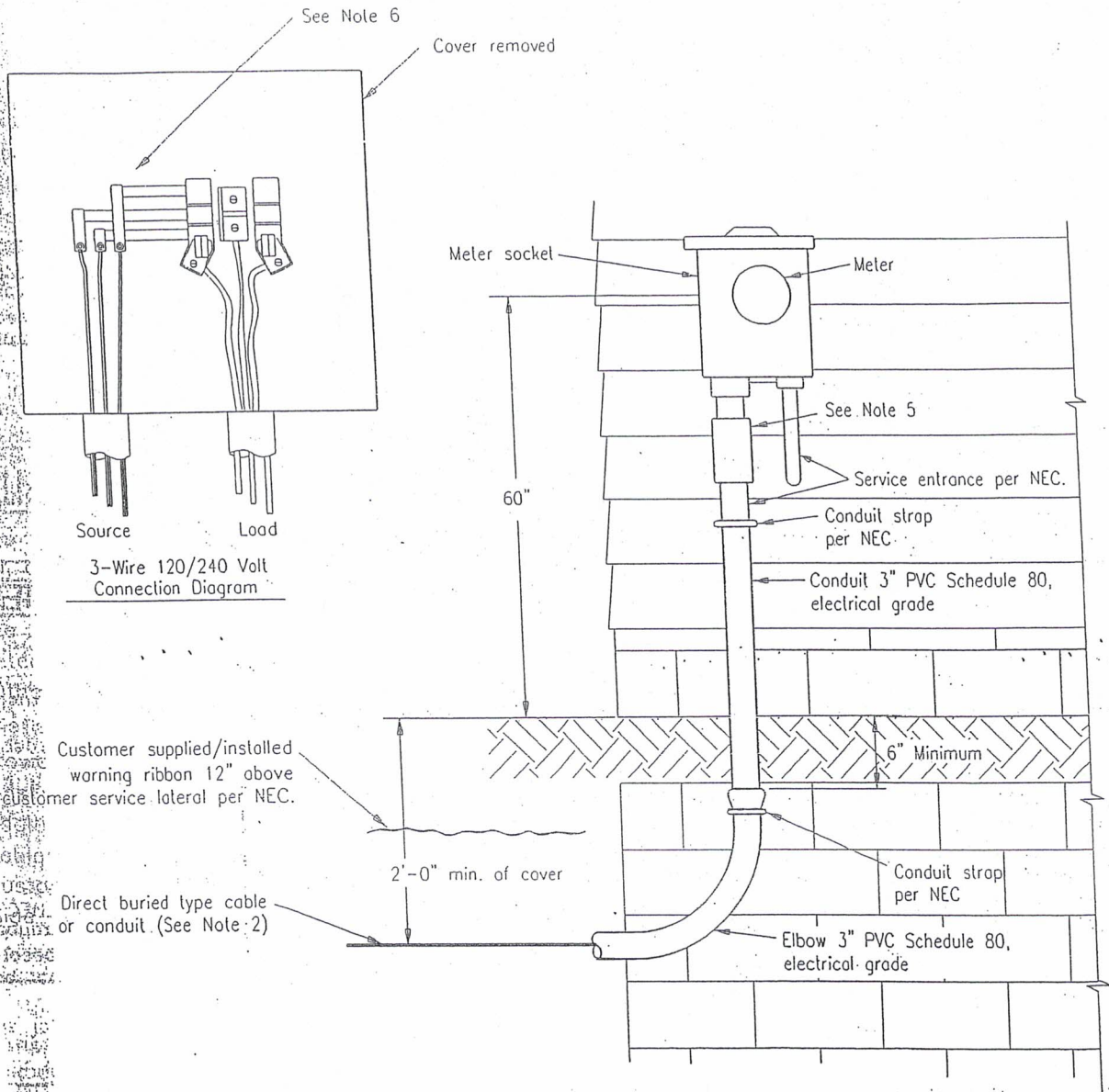

NOTES

1. For customer/Company responsibilities, see Exhibit 1.
2. For trenching and conduit details, see Exhibit 24.
3. See Section 6.0 for underground service details.
4. Meter socket may be connected to external ground rods, if required by the local inspection authorities.
5. The customer shall provide a well tamped and firm trench (see Exhibit 24). The customer shall provide ground movement protection per NEC 300.5(J) to prevent damage due to settlement or frost heaves. The Company recommends that the customer use a slip-joint conduit product. Additionally, sufficient slack or a slack box should be provided by the customer to allow for cable movement. For a 3-inch dia. conduit installation, the Company recommends that the customer install a slip joint with an attached slack box.
6. Side-bussed meter socket only.

TYPICAL SINGLE-PHASE UNDERGROUND SERVICE LATERAL INSTALLATION 400 AMP OR LESS

FirstEnergy.

Service Guide	REV.
	0
EXHIBIT 8	DATE
	7/14

PA

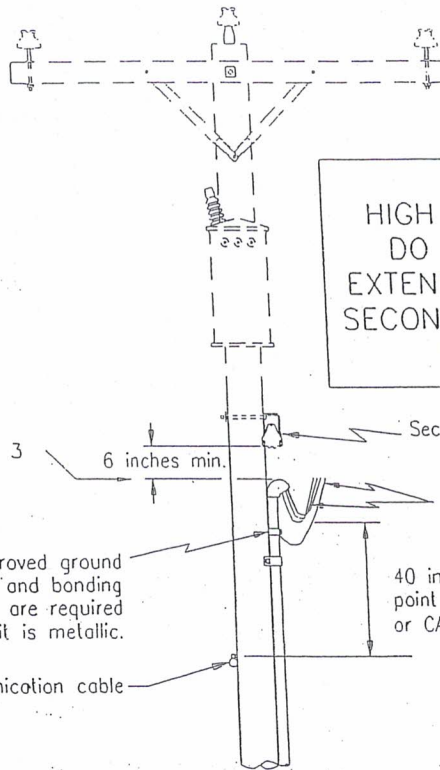

DANGER
 HIGH VOLTAGE ABOVE
 DO NOT CLIMB OR
 EXTEND CONDUIT ABOVE
 SECONDARY OR NEUTRAL
 SEE NOTE 2

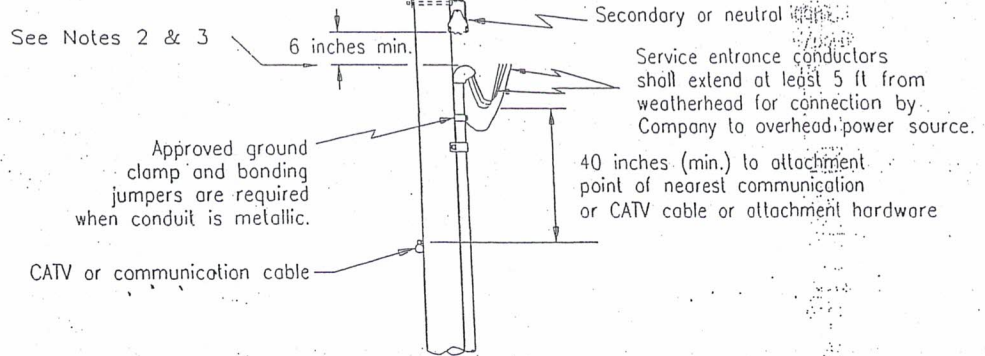

NOTES:

1. For customer/Company responsibilities, see Exhibit 1.
2. **CAUTION:** Only qualified personnel are permitted to install electrical equipment in the vicinity of energized electrical lines as described in OSHA 1910 Subpart R. & S.
3. Company shall determine the location/position of vertical risers on the pole based on traffic flow and location of CATV, or Telephone Co. attachments. Conduit shall maintain a minimum clearance of 6 inches below the secondary or neutral.
4. All service installations shall meet NEC, state, and local codes and regulations.
5. Customer shall provide additional continuous cable of sufficient length (5 ft minimum) to connect with overhead source.

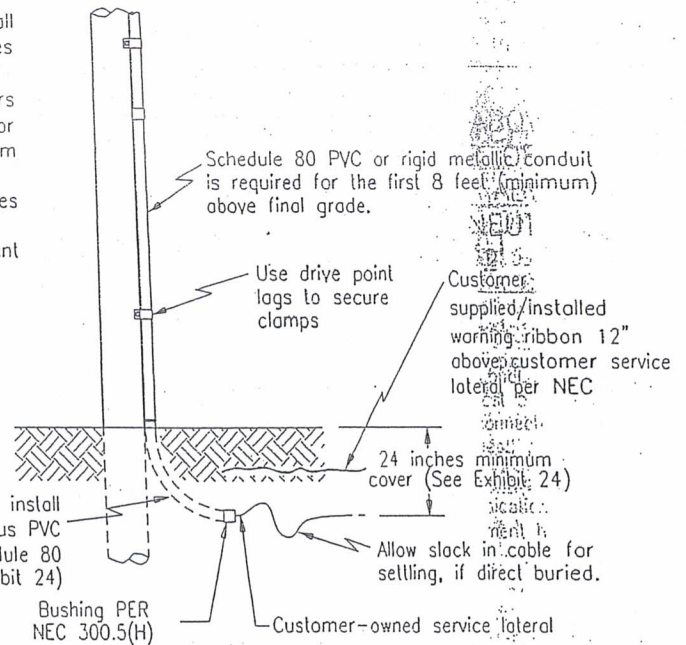

DIRECT ATTACHMENT OF CUSTOMER-OWNED UNDERGROUND SECONDARY SERVICE LATERAL(S) ON PENNSYLVANIA OPERATING COMPANY'S POLES

FirstEnergy	
Service Guide	REV.
	0
EXHIBIT 9	DATE
	9/14

Secondary/Service Conduit at Pole

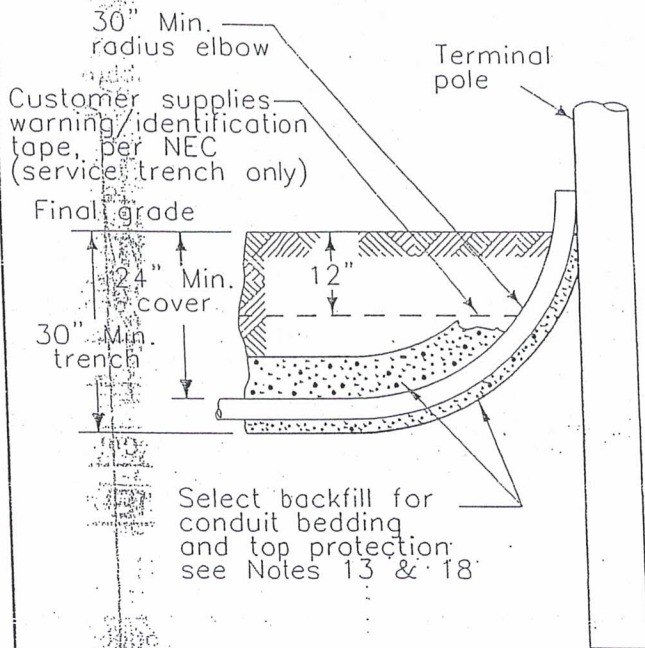

Secondary/Service Lateral Trench

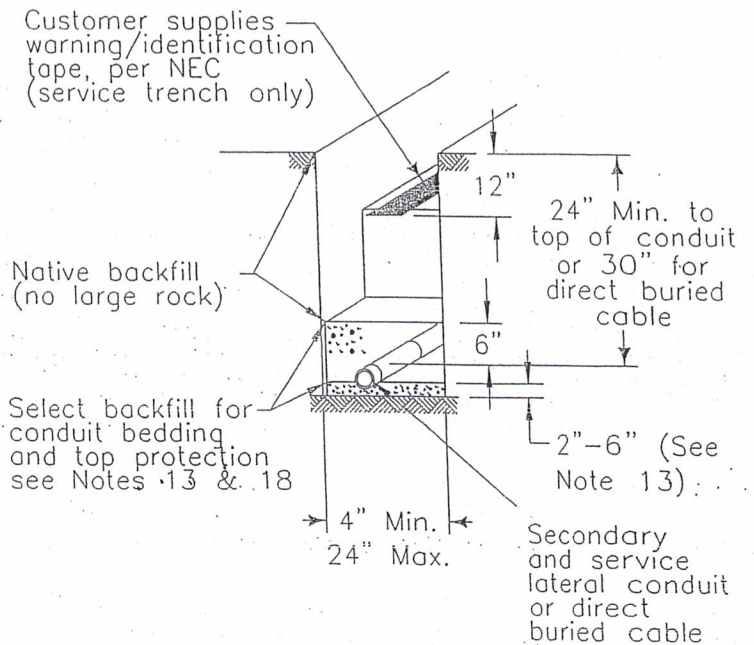

Primary Conduit at Pole

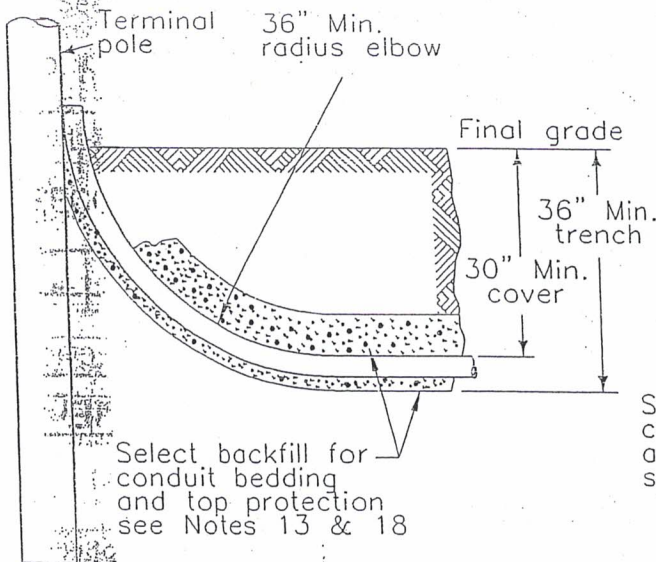

Primary Trench

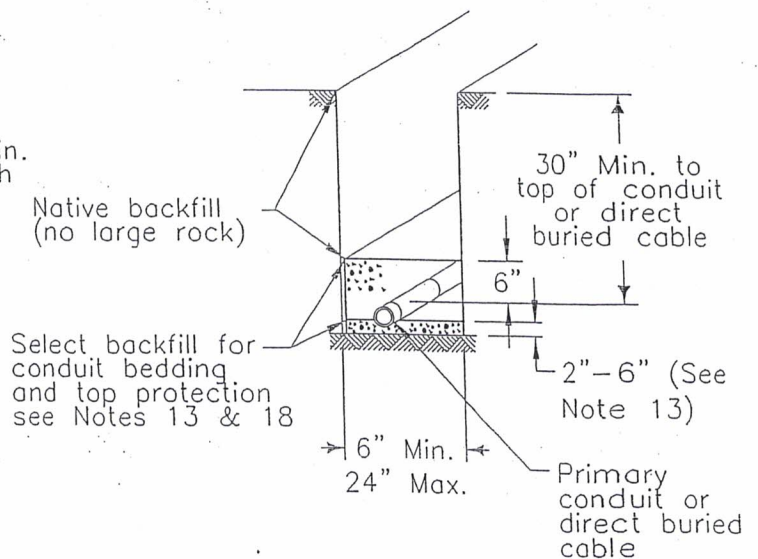

See Note 5 for joint-use trenches.

TYPICAL TRENCHING DETAILS FOR INSTALLATION OF
SECONDARY/SERVICE LATERAL & PRIMARY CONDUCTORS
(DIRECT BURIED OR CONDUIT)

FirstEnergy

Service Guide	REV.
	0
	DATE
	8/14

EXHIBIT 24

1. Customer shall provide trenching, conduit (when required), and backfill to Company requirements.
2. Customer/contractor shall contact Company for location of Company and customer electrical facilities and the approved trench route for connecting them.
3. The customer/contractor shall not deviate from the Company's approved trench route unless expressly approved by an authorized Company representative.
4. Before excavation begins, the excavator shall notify the appropriate state one-call agency (refer to Sections 3.13 and 3.14). The trench contractor shall be responsible for any damage caused by the excavator.
5. Applicant shall also coordinate the installation of all other buried utilities that are installing their facilities nearby, will jointly occupy the trench, or cross the electrical supply trench.
6. Minimum clearances between electric supply lines (direct buried or in conduit) and the following utility lines:
 - Steam or cryogenic lines - six (6) feet (use of an approved thermal barrier may reduce this clearance),
 - Fuel lines (gas, oil, propane, or other) - four (4) feet,
 - Water, sewer, & telecommunication (i.e., telephone & CATV) lines - one (1) foot,
 - Clearances from telephone & CATV lines may be reduced to 0 ft or no deliberate separation (a.k.a. random lay) if all involved parties agree and NESC Rules are met,
 - Other utility companies (e.g., local water, sewer, and fuel) may require greater clearances than stated above,
 - If required (e.g., trenching through solid rock) clearances may be reduced to one (1) foot minimum if all involved parties agree,
 - Other facilities are prohibited from running above/below and parallel to the electrical cable without specific Company's approval.
7. The Company's minimum trench dimensions are based on providing adequate cover per NEC and NESC codes (depth) and acceptable working areas (width). Minimum cover shall be maintained at all times. See drawings for trench dimensions. Customer should contact the Company. if the trench must be more than four (4) feet deep.

Owner (Code)	Customer-Installed Facilities (NEC) (Inches)				Company (NESC) (Inches)
	Direct Buried Cable	Rigid Metallic Conduit (RMC)	Rigid Nonmetallic Conduit (RNC)	Street/Road Parking Lot (Note 21)	Direct Buried Cable
0 - 600 V	24	6	18	24	24
> 600 V - 22 kV	30	6	18	24	30
> 22 kV - 40. kV	36	6	24	24	30

8. Customer shall clear the cable route of trees, tree stumps, boulders, or other obstructions. The excavator shall grade the trench route to final grade level.
9. Customer/contractor shall not use power-excavating equipment within 18 inches of any existing buried cables or other electrical or communications equipment.
10. Because of changing weather conditions and possibility of cave-ins, the excavator should not open the trench any more than 24 hours before Company scheduled work. If a cave-in occurs, it is the customer/contractor responsibility and expense to retrench before the Company can do its work.
11. Excavated material ("spoils") should be placed on the field side of the trench (unless directed by the Company otherwise), two (2) feet from the edge of excavations (per OSHA Standard 1926.651(j) (2)).
12. Standing water in the trench should be removed by pumping or draining (per OSHA Standard 1926.651(h)).
13. The bottom of the trench shall be relatively smooth, undisturbed earth, well-tamped earth, or sand, which is free of rock, cinders, or sharp objects. For direct buried cables, a six (6) inch layer of select bedding (sand or screening) may be required in certain soil conditions. Customer shall consult with the Company.
14. Conduit may be required in certain locations. Customer shall consult with the Company.

**TYPICAL TRENCHING DETAILS FOR INSTALLATION OF
SECONDARY/SERVICE LATERAL & PRIMARY CONDUCTORS
(DIRECT BURIED OR CONDUIT) GENERAL NOTES**

FirstEnergy.

Service Guide	REV.
	0
EXHIBIT 24	DATE
	8/14

15. If conduit is used, secondary and service lateral conduits shall be sized per NEC. Use Schedule 40 PVC, electrical grade conduit and a 30-inch minimum radius elbow at the terminal pole. Primary conduits are sized for the installation of primary conductors. Customer shall contact the Company for the proper primary conduit diameter. Primary conduit shall be Schedule 40 PVC, electrical grade conduit. Use a 36-inch minimum radius elbow at the terminal pole.
16. All joints shall be glued together. Conduit shall be cleaned and plugged at each end to keep water and dirt out. Customer shall install 1/4-inch, unbroken nylon or polypropylene pull rope inside the conduit.
17. Before backfilling, the customer/contractor shall verify that the Company and local electrical inspector have completed all required inspections of the trench (if required). In addition, the customer shall verify other utilities that were approved to use joint trench have completed their work.
18. The customer/contractor shall backfill around all cables and conduits with six (6) inches of approved backfill. Approved backfill shall be graded sand, stone dust, limestone dust, rock-free (1/4 inch or less diameter stones) earth, or topsoil. Materials that "set up" such as fly ash, culm, and foundry waste are not acceptable. The remainder of the trench shall be backfilled with native soil and not contain large rocks (greater than 4 inch) or rocks with sharp edges. An additional six (6) inches of mounded backfill is recommended to allow for settling.
19. Backfill should be compacted in six-inch layers by hand or using with pneumatic or vibrating tamping equipment to lessen the effects of settling. Note: "Machine compaction should not be used within six (6) inches of the cable" (per NESC Rule 353A).
20. The customer/contractor shall bury warning tape above all customer-owned cables or conduits (per NEC 300.Sd (3)). The warning tape shall be placed in the trench at least 12 inches above the cable or conduit.
21. For cables located beneath roads under PennDOT jurisdiction, cables shall be installed in conduit, have a minimum of 36 inches of cover, and shall be completely backfilled with #2 RC aggregate.

TYPICAL TRENCHING DETAILS FOR INSTALLATION OF
 SECONDARY/SERVICE LATERAL & PRIMARY CONDUCTORS
 (DIRECT BURIED OR CONDUIT) GENERAL NOTES

FirstEnergy.

Service Guide	REV.
	0
EXHIBIT 24	DATE
	7/14

BUILDER INSTALL REQUEST

FORM 1046 (REV. 03-14)

Please Type or Print
Check the Appropriate Boxes Below

OPERATING COMPANY

Berlin Electric System

DETAILS OF SERVICE REQUIREMENTS

TEMPORARY ONLY (Fee Will Be Assessed) PERMANENT TEMP TO PERM (Fee May Be Assessed)

BUILDER INFORMATION

REQUESTED BY	BUILDING COMPANY NAME	COMPANY PHONE NO.
CONTACT PERSON	CONTACT PHONE NO.	FAX NO.

* If service application is in the "builder's "name, the "buyer" must contact us when it is time to transfer service.

BILLING NAME AND MAILING INFORMATION

NAME OF PARTY RESPONSIBLE FOR THE ELECTRIC BILL	SOCIAL SECURITY NO./TAX ID	CONTACT PHONE NO.	
E-MAIL ADDRESS			
STREET ADDRESS (MAILING)	CITY	STATE	ZIP CODE

LOCATION WHERE SERVICE IS NEEDED

NAME OF DEVELOPMENT OR ALLOTMENT	LOT NO.		
BUILDING NO.	FLOOR NO.	ROOM/APARTMENT/UNIT NO.	
STREET ADDRESS	CITY	STATE	ZIP CODE
COUNTY/TOWNSHIP/BOROUGH/TAX DISTRICT	NEAREST CROSS STREET/POLE NO.		

CONNECTION TYPE

UNDERGROUND OVERHEAD SQ. FT. OF STRUCTURE SET BACK FROM ROAD (In Feet)

PREMISE TYPE

Is this application for a multi-tenant structure? YES NO If yes, how many units? _____
Please attach a separate page with the list of street addresses and lot numbers.

RESIDENTIAL
 HOUSE MOBILE HOME APARTMENT DUPLEX TOWNHOUSE OTHER _____

NON-RESIDENTIAL
 COMMERCIAL INDUSTRIAL CABLE COMPANY EQUIPMENT TYPE OF STRUCTURE/SITE USE _____

SERVICE ENTRANCE

AMPERAGE 100 200 OTHER _____ VOLTAGE 120/240 120/208 277/480 OTHER _____ PHASE SINGLE PHASE THREE PHASE

DETAILS REGARDING STRUCTURE

HEATING SYSTEM	HEAT SOURCE	HEAT TYPE
	<input type="checkbox"/> ELECTRIC <input type="checkbox"/> PROPANE <input type="checkbox"/> OIL <input type="checkbox"/> KEROSENE <input type="checkbox"/> GAS <input type="checkbox"/> UNKNOWN <input type="checkbox"/> OTHER (DESCRIBE) _____	<input type="checkbox"/> GEOTHERMAL HEAT PUMP <input type="checkbox"/> HOT WATER/STEAM <input type="checkbox"/> BASEBOARD <input type="checkbox"/> ADD-ON HEAT PUMP <input type="checkbox"/> HOT AIR/ELECTRIC FURNACE <input type="checkbox"/> UNKNOWN <input type="checkbox"/> OTHER (DESCRIBE) _____
WATER HEATER	HOT WATER SOURCE	HOT WATER TYPE
	<input type="checkbox"/> ELECTRIC <input type="checkbox"/> GAS <input type="checkbox"/> OIL <input type="checkbox"/> PROPANE	<input type="checkbox"/> STORAGE TANK <input type="checkbox"/> OTHER _____ <input type="checkbox"/> TANK LESS <input type="checkbox"/> SIZE IN GALLONS _____
AIR CONDITIONER	COOLING TYPE	WELL PUMP
<input type="checkbox"/> YES <input type="checkbox"/> NO TONS _____	<input type="checkbox"/> CENTRAL AIR <input type="checkbox"/> HEAT PUMP <input type="checkbox"/> WINDOW/WALL	<input type="checkbox"/> YES <input type="checkbox"/> NO <input type="checkbox"/> UNKNOWN

OTHER HIGH USAGE APPLIANCES/EQUIPMENT:

NAME OF ELECTRICIAN: _____ PHONE NO.: _____

STAGE OF CONSTRUCTION STAKED FOUNDATION FRAMED UNDER ROOF OTHER _____

DIRECTIONS/COMMENTS

